



amicidella bottega
delle mani
Craft_Design & Landscape

ARIANO ed il MUSEO ANTICRISI

relazione
Mario Pagliaro
ceramiche
Flavio Grasso
fotografie
Marco Ciano

www.bottegedellemani.com

**A me, della
Ceramica di Ariano
Irpino, importa ben
poco...**

**... come, del resto, di
tutte le cose
semplicemente belle
che non portano a
niente.**

**“Se ha un senso parlarne,
studiarla, insegnarla,
comprenderla é solo per le
implicazioni positive che
potrebbe avere sulle logiche di
sviluppo sostenibile di un
territorio.”**



**Lo strano caso
della
“Santa Barbara”
della nuova
maiolica arianeese**

















1_L'altare

Il basamento è costituito da un monolite di Marmo Giallo Reale con uno spessore delle pareti di 5 cm, svuotato al suo interno al fine di ridurre il peso.

La lastra superiore è realizzata in un unico pezzo di Marmo Bianco P;

il medaglione centrale è in ceramica invetriata rifinita con lustro "oro zecchino brillante".



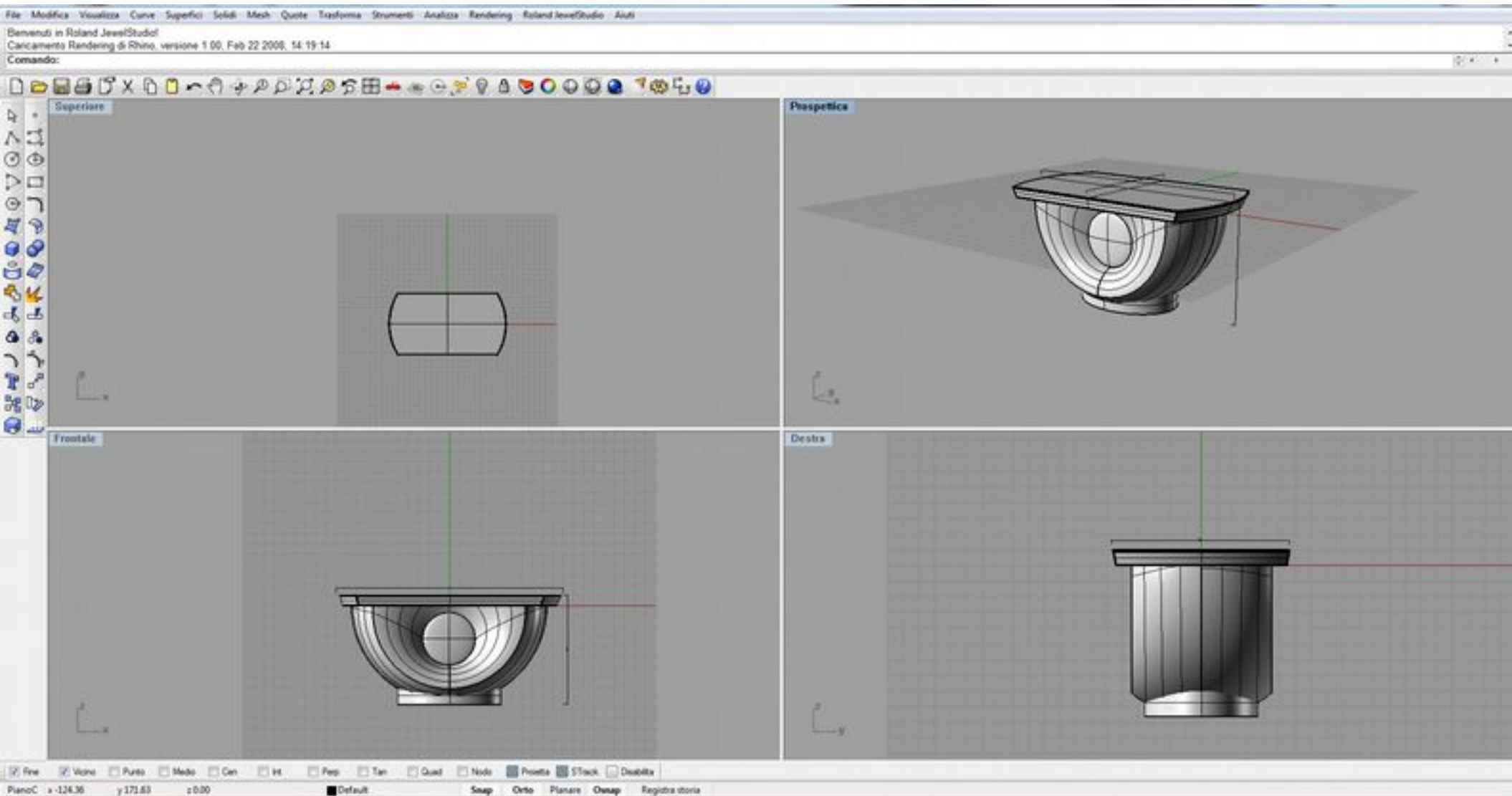

ALTARE

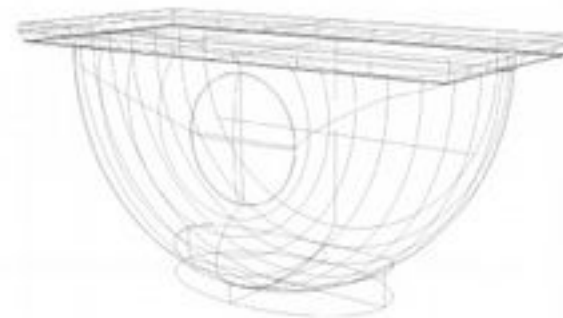
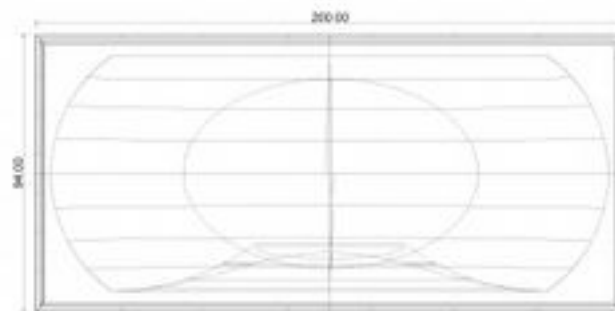
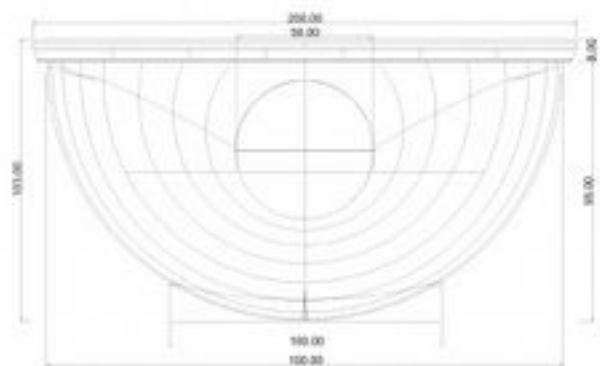
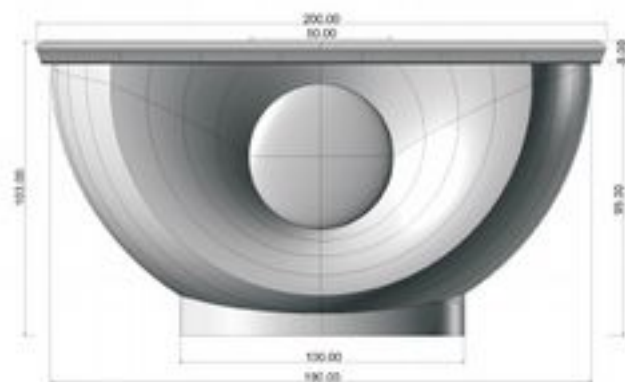

ALTARE



Disegno del medaglione centrale
realizzato in basso rilievo
in ceramica invetriata fondo bianco,
blue lustro oro

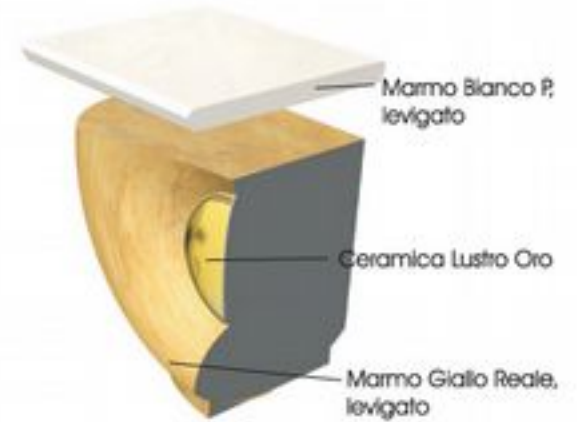
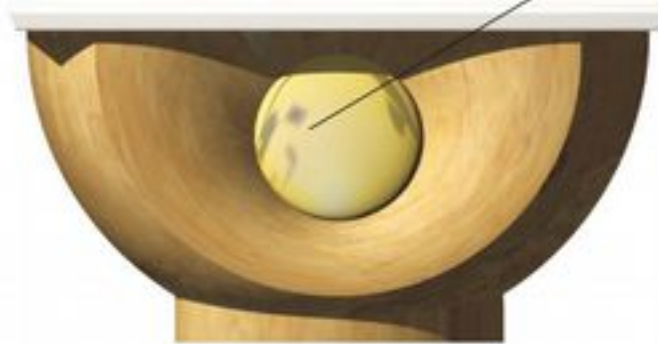













2_L'ambone

La struttura è realizzata in cemento rivestita da un bassorilievo in ceramica invetriata.

La struttura sulla parte superiore e laterale è racchiusa da Marmo Bianco P.

La ceramica invetriata è rifinita esclusivamente con l'uso di lustro oro e madreperla.



AMBONE

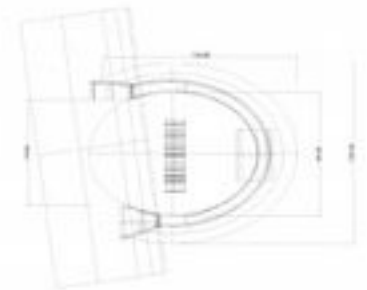
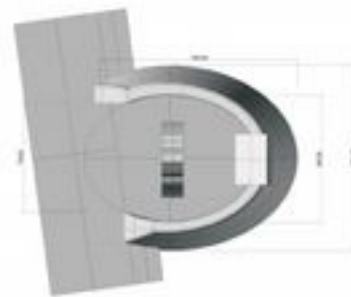
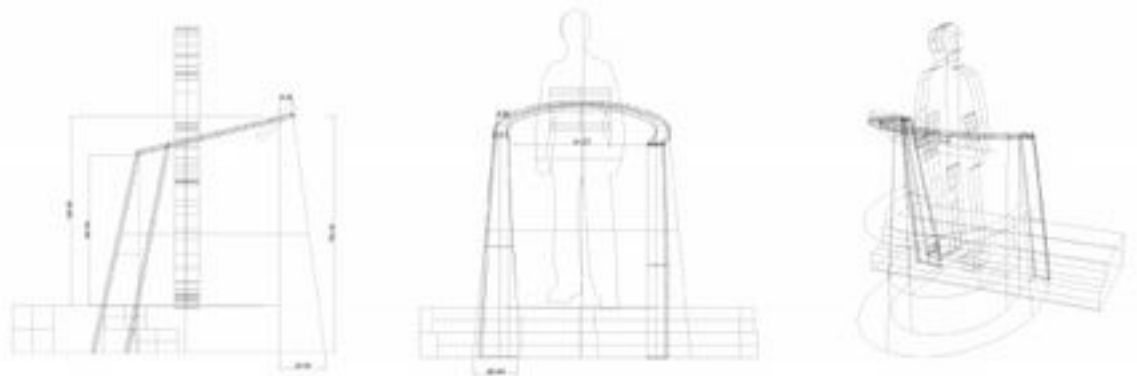
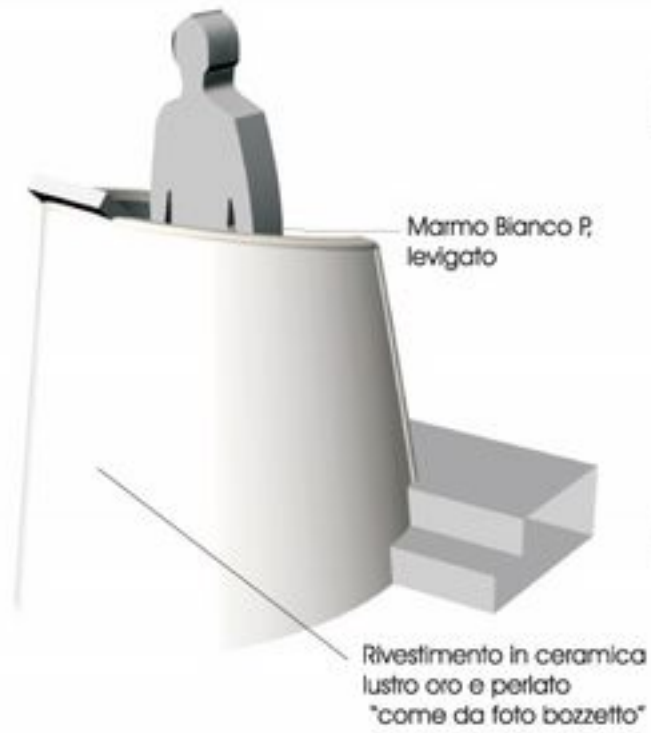

Ambone



Diseño del bajo relieve
raffigurante i simboli
dei 4 evangelisti



Foto bozzetto Ambone



Ceramica invetriata con lustro oro e madreperla







3_Il tabernacolo

La base del tabernacolo è realizzata in cemento rivestita con la stessa graniglia del pavimento.

Nella parte centrale del basamento è inserita la ceramica invetriata dorata.

Il tabernacolo è realizzato in ottone dorato (in bagno galvanico oro) incastonato in blocchi di Marmo Bianco P.



TABERNACOLO

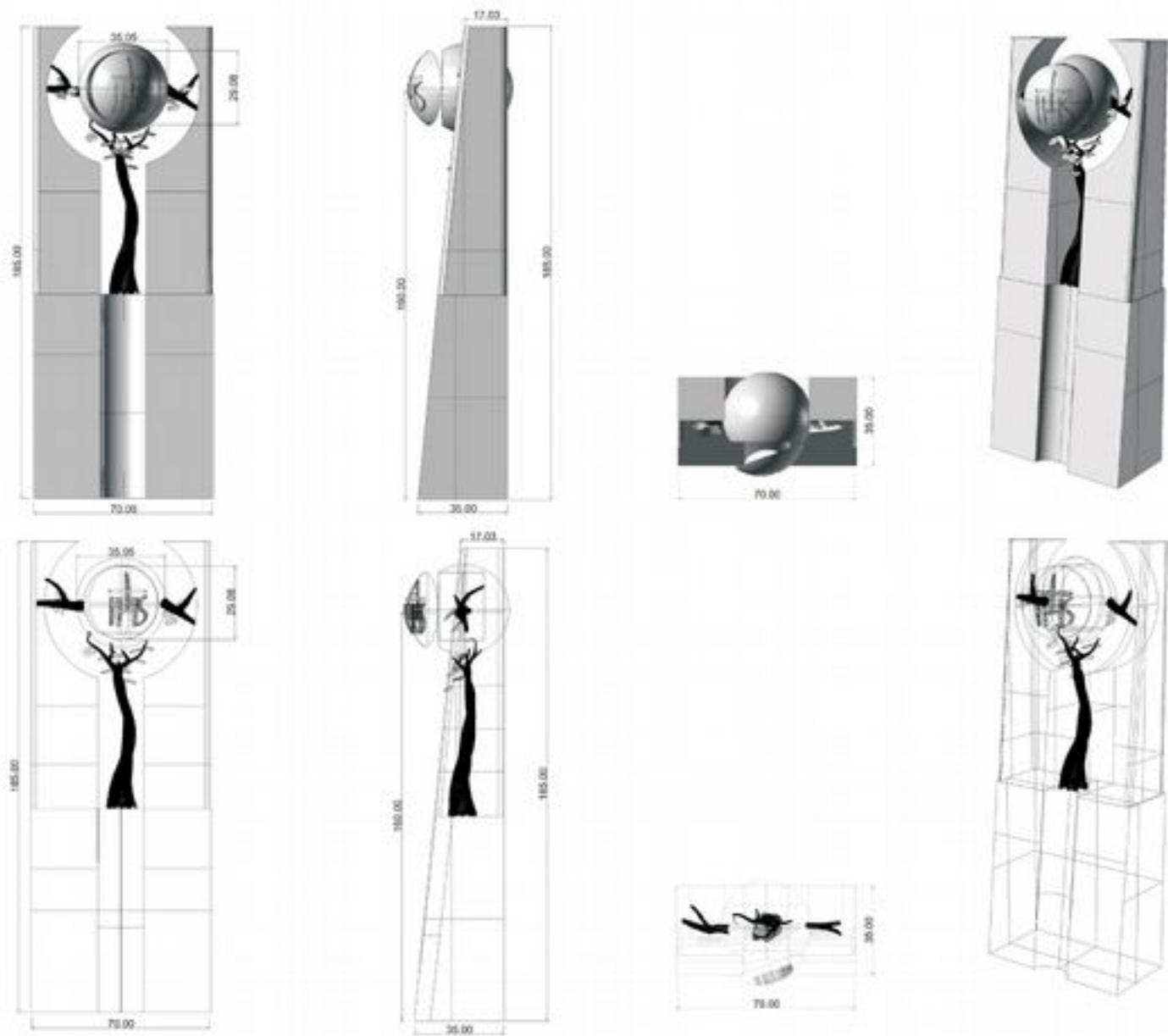

TABERNACOLO

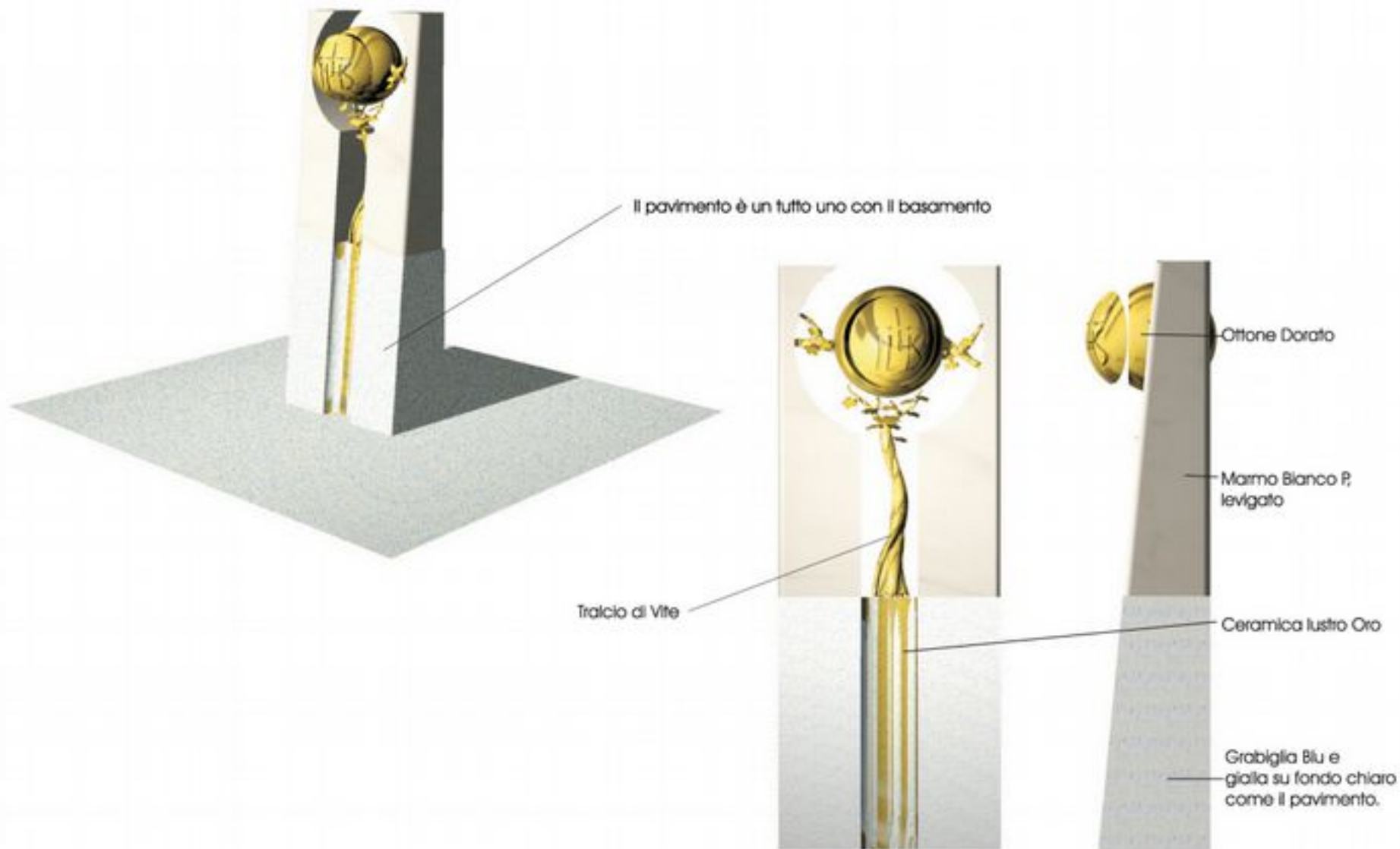









4_La Sedia

La sede celebrante è completamente realizzata in legno massello di faggio parzialmente intagliato a mano.

La finitura è eseguita con vernice semi lucida.





SEDE DEL CELEBRANTE

Particolare schienale



Ceramica
invevriata blu

Legno di Faggio
finitura semilucida

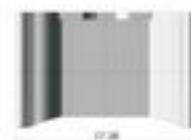
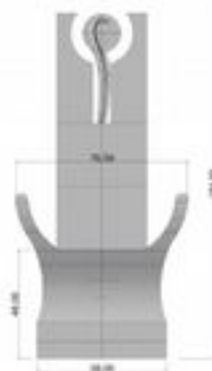
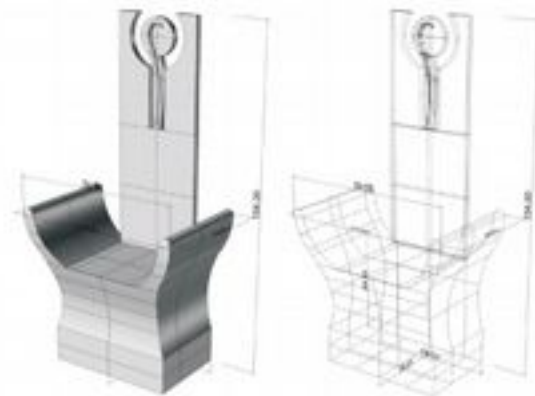
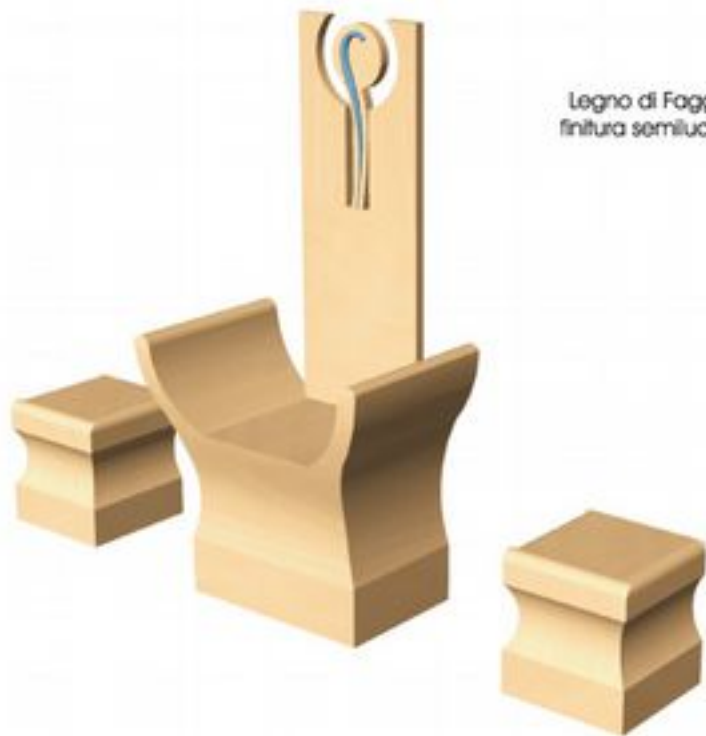







5. Le acquasantiere

Blocco in Bianco
Marmo P.
con ceramica
invetriata azzurra,
applicata a rilievo



ACQUASANTIERA

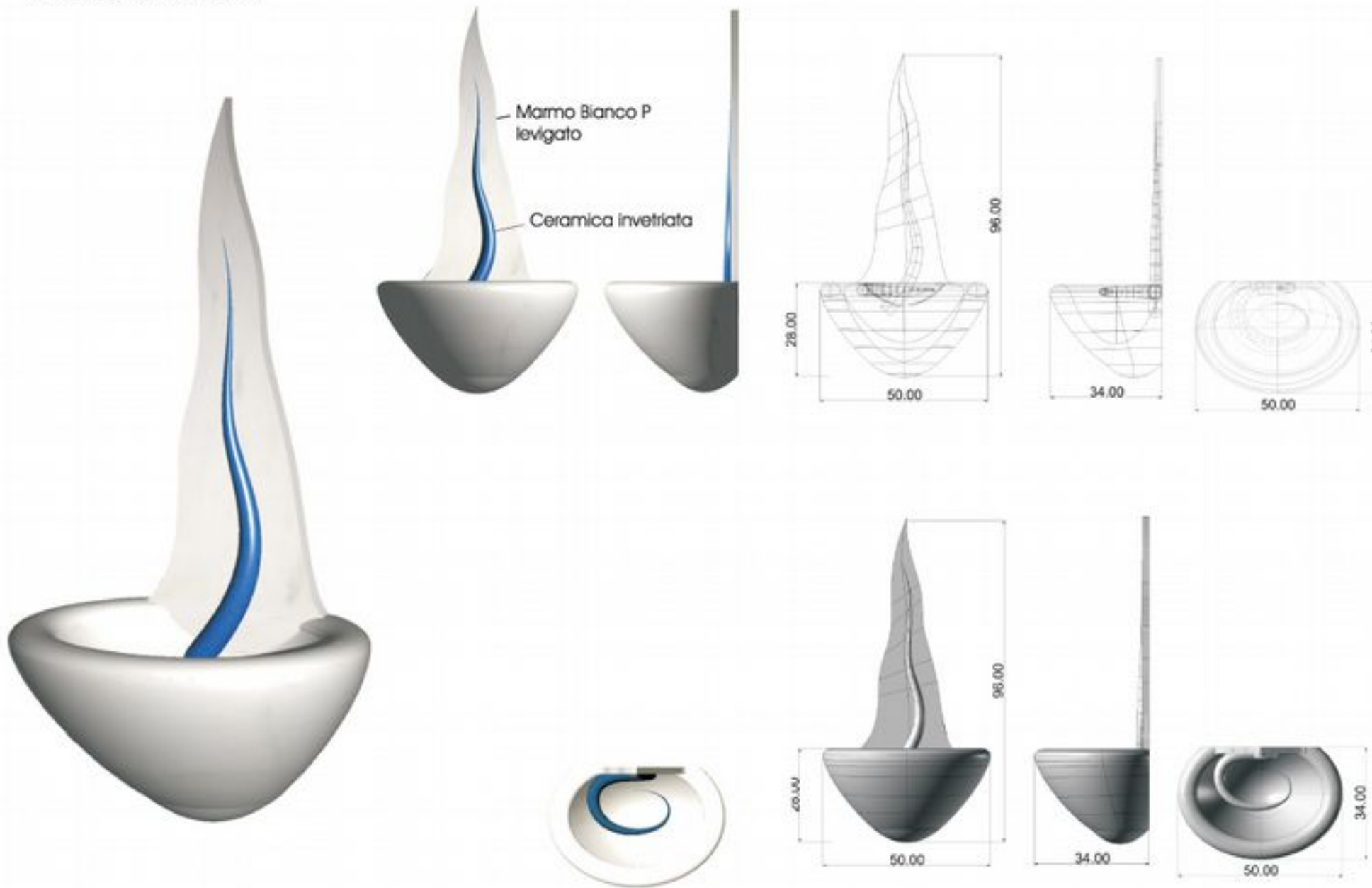





6.11 crocefisso

Il Cristo è realizzato
in terra refrattaria
bianca

La croce in legno di
ciliegio a finitura
lucida, con piccole
striature di stucco
blu.

Misure 240x170cm











7_Il fonte battesimale

Il basamento è di Marmo Giallo Reale a forma ottagonale con inserti di ceramica invetriata, mentre sul lato posteriore sono installati i comandi di scarico dell'acqua.

La parte superiore è in Marmo Bianco P.

FONTE BATTESIMALE

Schizzi per i basso rilievo
in ceramica policroma invetriata e lustro oro



Vasca raffigurante un pesce



Raffigurazione
del Battesimo del Cristo



FORNTE BATTESIMALE

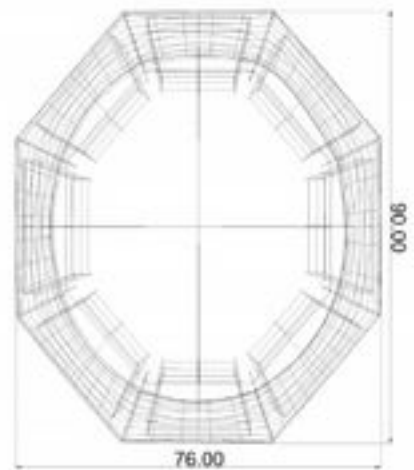
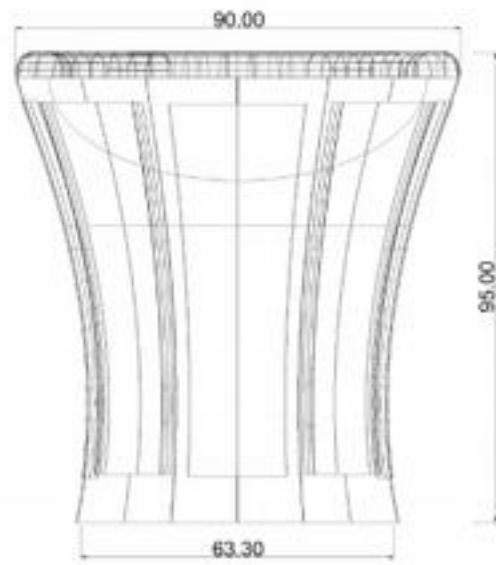
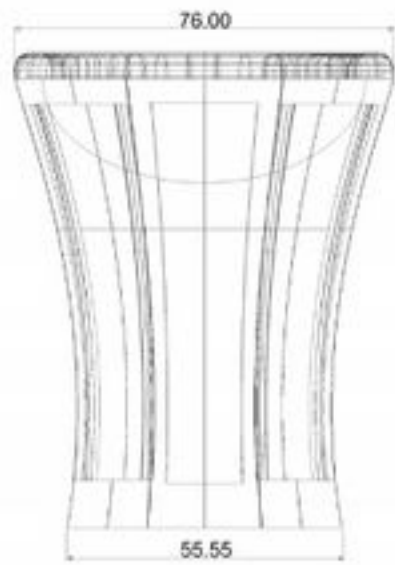
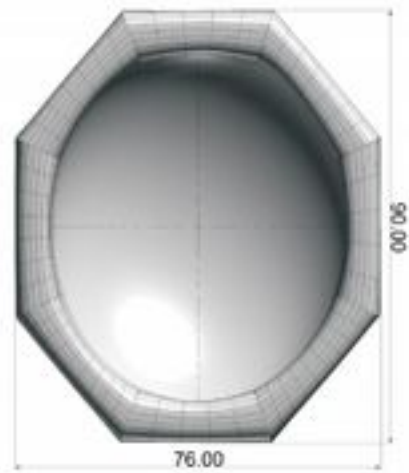









...a, realmente, tessuto produttivo, nel senso della disponibilità all'innovazione, alla collaborazione ed al coinvolgimento di filiera. Per questo, la nuova Santa Barbara, rappresenta una novità positiva, io lo guarderei come una nuova stanza del museo della Ceramica, finalmente una testimonianza di come, quel che si dice, possa portare ad altro che non sia retorica.”

© RIPRODUZIONE RISERVATA

Uno delle